

DIN 2634 WELDING-NECK FLANGES

9.13

DN 200 - 600
PN 25

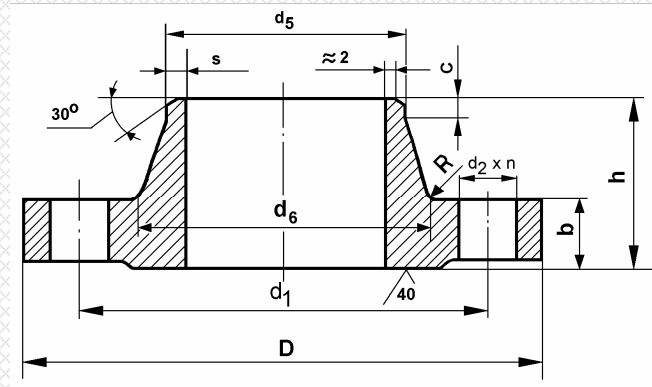

Application:

Applied as counter flanges to connect pipes and install valves in pipeline systems.

Material quality:

Up to order
(Carbon, alloy or stainless steel)

DN	D	b	h	d5	d5	s	d6	d1	d2	n	R	c	kg
200	360	30	80	219,1	219,1	5,9	244	310	26	12	10	16	16,5
250	425	32	88	273	273	6,3	298	370	30	12	12	18	23,6
300	485	34	92	323,9	323,9	7,1	352	430	30	16	12	18	31,2
350	555	38	100	368	355,6	8	398	490	33	16	12	20	45,0
400	620	40	110	419	406,4	8	452	550	36	16	12	20	58,0
500	730	44	125	521	508	8	558	660	36	20	12	20	88,4
600	845	46	125	610	610	8,8	660	770	39	20	12	22	101,0

DN 15-150: PN 25=PN 40